

Batch Cooker



Features

- High performance shaft set up for short batch times.
- Heated shell and shaft.
- Capacities up to 11.000 kg/batch.
- Less exposure to heat, causing a positive effect on the nutrient value of the end product.
- Strong underframe for easy installation and simplifies piping.
- Frame mounted gear reducer and drive for strength and rigidity.
- TÜV / PED / GOST R/GOST K/GOST B/GGTM Code construction for internal and jacket working pressure.



MAVITEC

Batch Cooker

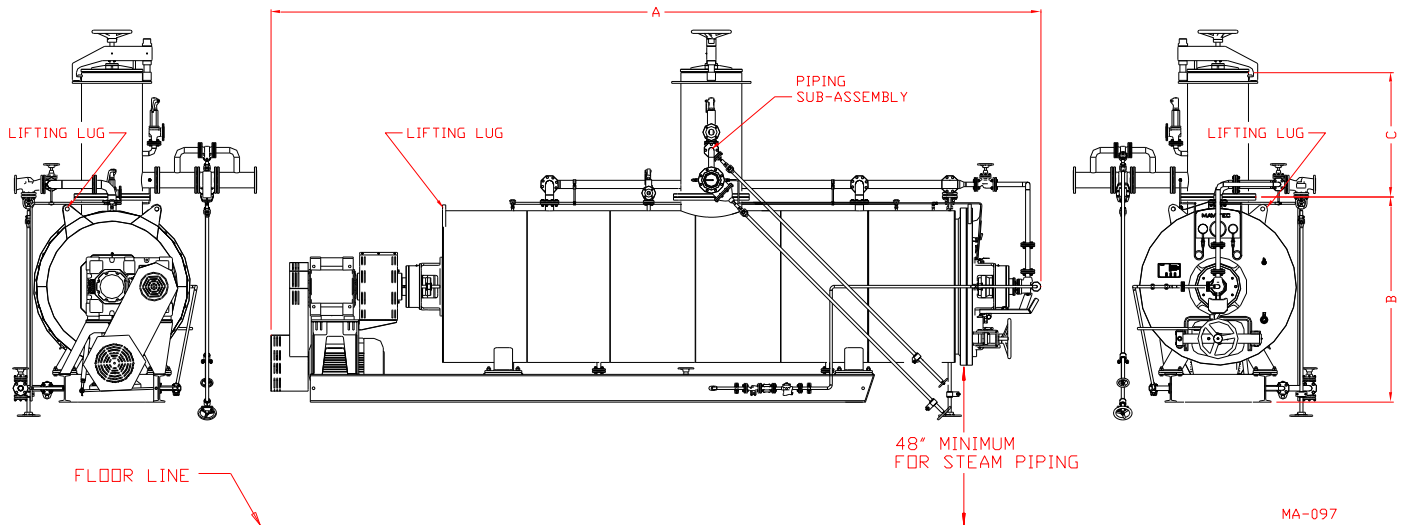

Specifications

Cooker	Approx.					
Model	Capacity	Power	Weight	Length (A)	Height (B)	Height (C)
	kg/batch	kW	Kg	mm	mm	mm
1800	1100	11	4500	3600	1600	Var
3500	2200	15	8750	5700	1900	Var
5000	3500	37	11000	5700	2200	Var
7200	4600	55	19000	7600	2200	Var
8500	5500	55/75	22000	8500	2200	Var
10000	6300	75	28000	9000	2600	Var
12500	7800	110	32000	10500	2600	Var
16000	9700	110	37000	10500	2800	Var
18000	11000	132	40000	10500	3000	Var

Due to ongoing product improvements, data shown here is subject to change without notice.
Contact Mavitec B.V. for latest specifications.

MAVITEC

Galileistraat 20, 1704 SE Heerhugowaard, The Netherlands
Tel.: +31-72-574 59 88 - Fax: +31-72-574 55 48
E-mail: info@mavitec.com - www.mavitecgreenenergy.com

DUPPS

Germantown, Ohio U.S.A.
Tel: +1-937-855 6555 • Fax: +1-937-855 6554
E-mail: info@dupps.com • www.dupps.com